

Ball Valves INTEC

K231, 3" - 12", Class 150/300
trunnion mounted ball, metal seated,
single side spring loaded seat ring, free outlet

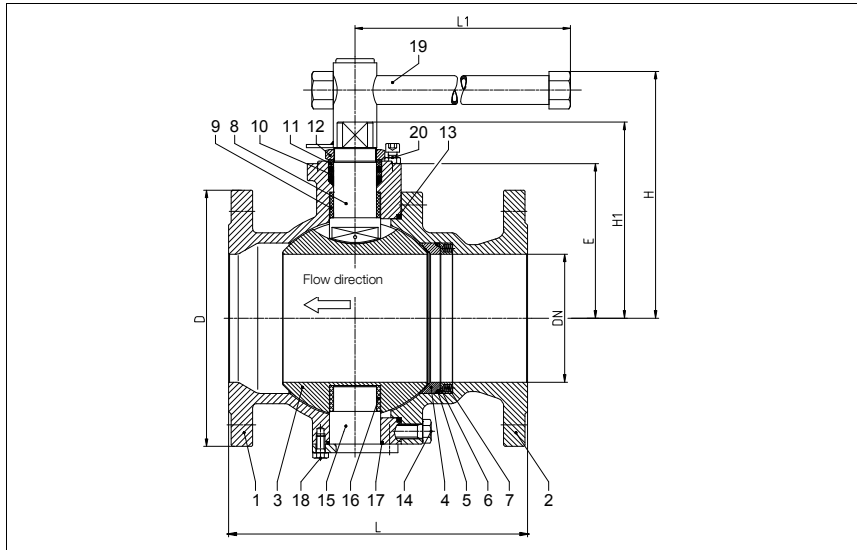

Flanged ball valve
full bore
face to face acc. to ANSI B 16.10
flanges acc. to ANSI B 16.5

Specification:

Two-piece ball valve, flanges acc. to ANSI B 16.5, face to face dimensions acc. to ANSI B 16.10, full bore, free outlet, blow-out-proof stem, body material stainless steel (ASTM A351-CF8M) or carbon steel (ASTM A216-WCB), antistatic device, free of non ferrous metals, trunnion mounted ball, seat 1.4571 (AISI 316 Ti)/ 1.4404 (AISI 316 L) hard facing metal coated, single side spring loaded seat ring, stem packing cone ring system acc. to temperature use, dynamic loaded adjustable, top flange DIN EN ISO 5211, approved by PED, certified acc. to GERMAN clean air act VDI 2440, Fire-Safe acc. to DIN EN ISO 10497, with lever.

Marking: INTEC K231

No.	Part	Material	Material
High temperature design			
1	body	A216-WCB	ASTM A351-CF8M
2	cap	A216-WCB	ASTM A351-CF8M
3	ball	1.4408 (ASTM A351-CF8M) hard facing metal coated	
4	seat	1.4571 (AISI 316 Ti)/1.4404 (AISI 316 L) hard facing metal coated	
5	bearing ring seal	Graphite	
6	follower ring	1.4571 (AISI 316 Ti)/1.4404 (AISI 316 L)	
7	spiral spring	Inconel X750	
8	stem	< 250°C 1.4462 (A479 UNS S31803)	350°C 1.4313 (A479 UNS S41500)
			400°C 1.4980 (A638-660)
9	stem bearing	E-carbon	
10	upper seal	1.4571 (AISI 316 Ti)/1.4404 (AISI 316 L)/Graphite	
11	bearing	E-carbon	
12	hex. nut self-locking	A2/1.4301 (AISI 304)	
13	body seal	Graphite	
14	hex. screw	A4-70 (A193-B8M)	
15	trunnion (< NPS 5" with screwed end)	1.4571 (AISI 316 Ti)/1.4404 (AISI 316 L)	
16	bearing	E-carbon	
17	trunnion seal	Graphite	
18	hex. screw (as from NPS 6")	A4-70 (A193-B8M)	
19	lever	1.4408 (ASTM A351-CF8M)/1.4308 (ASTM A351-CF8)	
20	stopper	A2	
Fire-Safe design			
9	below seal	KFGN/Graphite	
	bearing	1.4401 (AISI 316)/KF	
10	upper seal	KFAM/Graphite	
11	Fire-Safe seal	Graphite	
	ring	1.4571 (AISI 316 Ti)/1.4404 (AISI 316 L)	
	thrust washer	PEEK	
13	combined body seal	KF-Graphite	
16	bearing	1.4401 (AISI 316)/KF	
Standard design			
5	bearing ring seal	KF	
7	spiral spring	1.4401 (AISI 316)	
9	below seal	KFGN/Graphite	
	bearing	1.4401 (AISI 316)/KF	
10	upper seal	KFAM/Graphite	
11	bearing	PEEK	
13	body seal	KF	
16	bearing	1.4401 (AISI 316)/KF	
17	trunnion seal	KF	

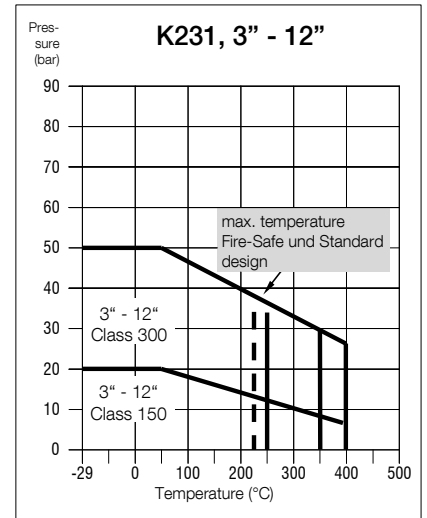

Ordering example:
INTEC K231, 4", Class 300, CF8M,
high temperature, 1.4980 (stem)

* Necessary torque measured with treated water at Δ P acc. to pressure class and room temperature

** Gearbox recommended

Dimensions

NPS inch	dimensions (mm)		L 150 lbs.	L 300 lbs.	D 150 lbs.	D 300 lbs.	E	H1	top flange ISO	torque		ca. weight	
	H	L1								Nm* 150 lbs.	Nm* 300 lbs.	kg 150 lbs.	kg 300 lbs.
3"	194	500	203	283	190	210	112.5	155	F10	229**	437**	23	30
4"	221.5	500	229	305	229	254	137	179.5	F12	393**	790**	35	46
6"	263	700	394	403	279	318	181	229.5	F12/F14	686**	1500**	78	96
8"	304	1000	457	502	343	381	225	284.5	F14/F16	1310**	3100**	145	172
10"	340.5	1200	533	568	406	444	261.5	321	F14/F16	1856**	4349**	245	287
12"	--	--	610	648	483	521	311	400	F16	2983**	7367**	356	406

Subject to technical modification. 08/2019